

SINGLE PHASE 15° CUTOUT & ARRESTOR BRACKET

SPECIFICATIONS

BASE: ALUMINUM, 356-T6
 ROD: SOLID, ELECTRICAL GLASS ROVING WITH ULTRA-VIOLET INHIBITORS. VEIL COATED.
 FITTING: ALUMINUM, 356-T6
 HARDWARE: STEEL, HOT DIP GALVANIZED

CATALOG NUMBER	PHASE SPACING "A" INCHES	MINIMUM ULTIMATE LOAD (LBS)		
		VERTICAL A	LONG B	TRANS. C
FLHR-1-12-C5	12	1800	1400	10,000
FLHR-1-15-C5	15	1500	1150	10,000
FLHR-1-18-C5	18	1200	900	10,000
FLHR-1-24-C5	24	900	700	10,000

RECOMMENDED WORKING LOAD 50% OF RATING LISTED

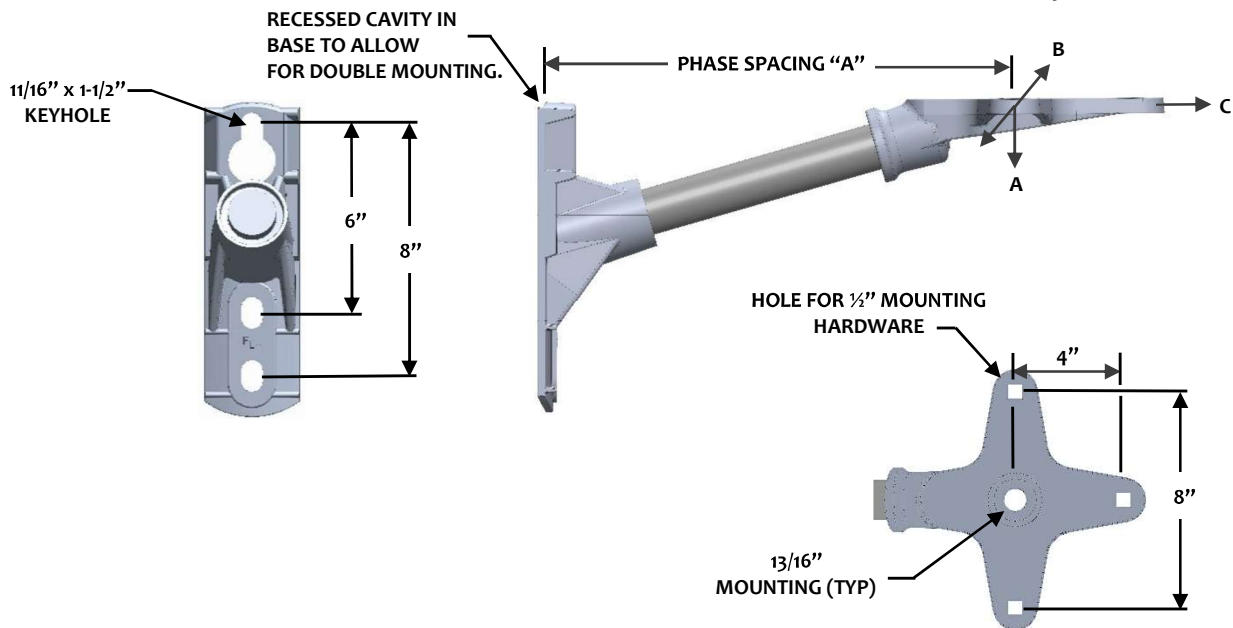

NOTE:

TO SPECIFY OTHER BASE OPTION, CHANGE FLHR WITH FLHF OR FLHL AS PREFERRED.
 FOR OTHER LENGTHS PLEASE CONTACT US. FOR BRACKET WITH (2) 1/2" CAPTIVE CARRIAGE BOLTS, SHAKEPROOF WASHERS, LOCK WASHERS AND HEX NUTS, ADD SUFFIX "H" TO CATALOG. (EXAMPLE: FLHR-1-12C5-H)
 TO SPECIFY SILICONE COATED ROD, ADD SUFFIX "SC" (I.E. = FLHR-1-12-C5-SC)